

NFORCER Traffic Arrow Manual

INSTALLATION

1. Remove endcap (side without cable) and insert mounting carriage bolts.
2. For Surface Mount, drill 1/4" (6.3mm) holes to the mounting surface.
3. Place Disk Gasket onto each bolt, and insert bolts into mounting holes.
4. Place Lockwasher and Elastic Stop Nut onto each bolt, and tighten firmly.
5. For Bracket Mount (sold separately), refer to mounting bracket manuals.

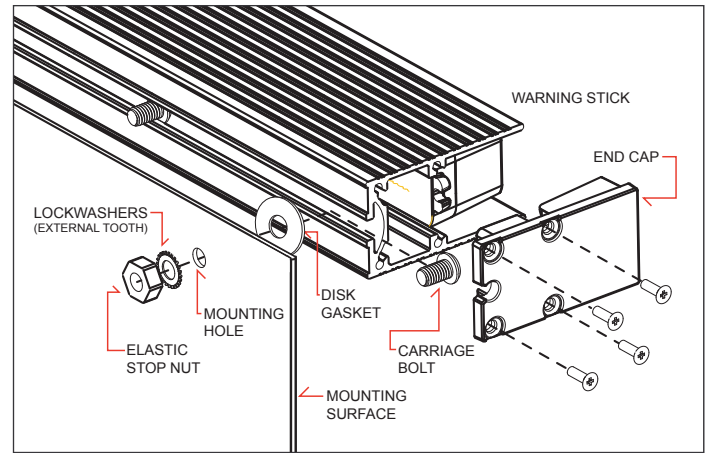

POWER WIRING

RED: to +VDC (with fuse according to the following chart)

Sticks with 3-LED Lightheads		
Heads	Max. Current	Fuse (Amps)
6	2.1	5
8	2.8	5
10	3.5	5

Sticks with 4-LED Lightheads		
Heads	Max. Current	Fuse (Amps)
6	4.2	10
8	5.6	10
10	7	10

BLACK: to Chassis Ground

CONTROL WIRING

WHITE: to +VDC for Low Power or disconnect for High Power

ORANGE: to +VDC for Left Arrow

BLUE: to +VDC for Right Arrow

BROWN: to +VDC for Center Out

YELLOW: for Flash Patterns (refer to Flash Patterns)

GREEN: on/off for end flasher heads (only for models with end flasher option)

Note: The correct side up is facing the front of the stick with wiring coming out the right side.

FLASH PATTERNS

Momentarily apply +VDC to YELLOW wire:

- Once for next pattern
- Quickly 3 times for reset to FP#1

FP#	ORANGE	BLUE	BROWN	ORANGE+BLUE+ BROWN
1	Single Left	Single Right	Single Center Out	Alternating Quad
2	Double Left	Double Right	Double Center Out	Alternating Mega
3	Triple Left	Triple Right	Triple Center Out	All Single
4	Solid Left	Solid Right	Solid Center Out	All Quad
5	Fade Left	Fade Right	Face Center Out	Left - Right

Note: This unit is not factory set at FP#1