

MINIMAX - JWPS0220 Installation Guide

Safety First

The Strobe Power Supply can be installed in many different types of vehicles. Important information is contained herein that could prevent serious injury or damage; the installer must read this manual completely before installation.

- Proper installation of this product requires the installer to have a good understanding of automotive electronics.
- When drilling holes, the installer MUST check both sides of the mounting surface to be sure that no vital vehicle components/parts could be damaged.
- Do not install where it'll interfere with the air bag. Refer to your vehicle owner's manual for the air bag deployment area. The User/Installer assumes full responsibility to determine proper mounting location, based on providing ultimate safety to all passengers inside the vehicle.
- If this product uses a remote device to activate or control this product, make sure that this control is located in an area that allows for easy and safe operation in any driving condition.
- It is recommended that this manual be stored in a safe place and referred to when performing maintenance and/or reinstallation of this product.

FAILURE TO FOLLOW THESE SAFETY PRECAUTIONS AND INSTRUCTIONS COULD RESULT IN DAMAGE TO THE PRODUCT OR VEHICLE AND/OR SERIOUS INJURY TO YOU AND YOUR PASSENGERS!

- I. **Mounting Power Supply.** Mount in an area where it is not exposed to excessive heat during normal operation of the vehicle and ensure that it's not exposed to potential damage from unsecured or loose equipment.

Warning: This is a high voltage device, do not touch or remove strobe light head while in operation. Wait at least 10 minutes after disconnecting from its power source before starting work or troubleshooting.

- II. **Installing Strobe Heads.** Install in head lights, tail lights or signal lights by drilling 1 inch holes. Route the harness from the Strobe Heads to the Power Supply.

- III. **Wiring Power Harness.** Connect RED wire to battery (+) or a fuse (at least 15Amps); connect BLACK wire to battery (-) or directly to vehicle chassis. Connect GREEN (HI/LO) wire to the user-supplied switch.

Warning: All user-supplied wires, that connect to the positive (+) terminal of the battery, must be sized to supply at least 125% of the maximum operating current, and fused "at the battery" to carry the load!

Note: Use the correct size wire for power connections. The length of the wires determines the size needed.

- ◇ 1 to 7 ft. use 18AWG wire.
- ◇ 7 to 14 ft. use 16AWG wire.
- ◇ 14 to 25 ft. use 14AWG wire.
- ◇ 25 to 35 ft. use 12AWG wire.

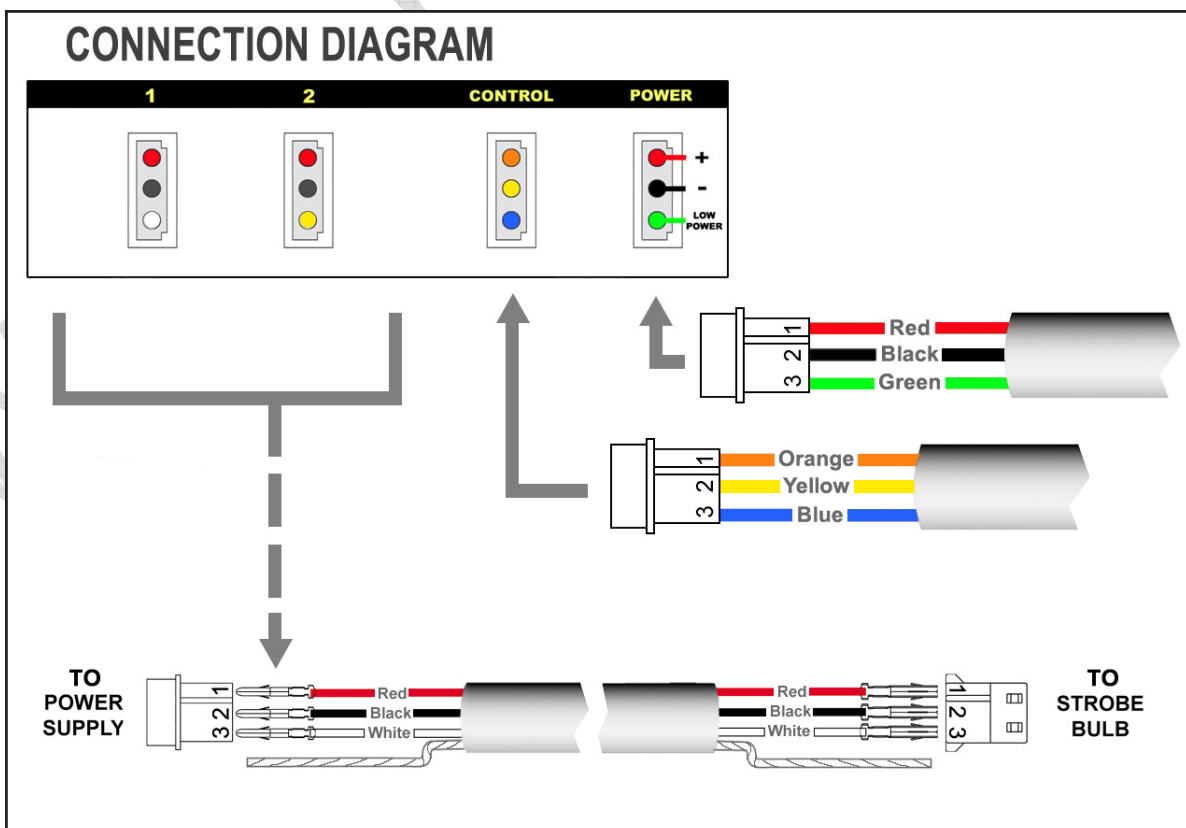

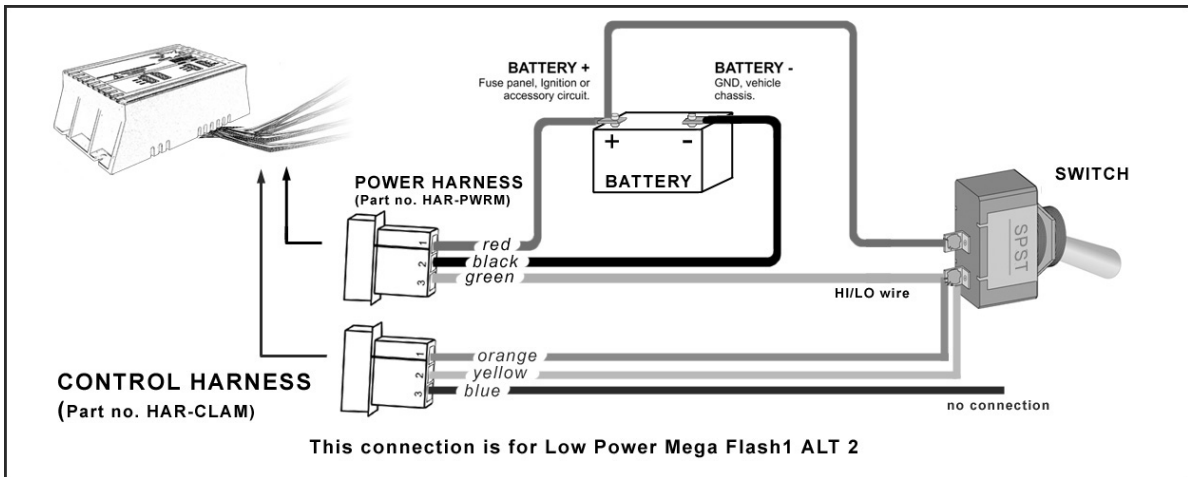

IV. Wiring Control Harness. Combination of different wires (ORANGE, YELLOW, BLUE) allow for different flash patterns; (see table). The GREEN wire from Power Harness enables High/Low Power function; (when off, it's at High Power, and when on, it's at Low Power). The remaining unused wires may be removed or left in place for future alterations.

Flash Pattern				
FP#	Blue	Yellow	Orange	FUNCTION
1				SHUTDOWN
2			POWER	Quad Flash 1 ALT 2
3		POWER		Quintuple Flash 1 ALT 2
4		POWER	POWER	Mega Flash 1 ALT 2
5	POWER			Double Flash 1 ALT 2
6	POWER		POWER	Single Flash (1&2) repeat 4x + Quint Flash 1 ALT 2 repeat 2x
7	POWER	POWER		Double Flash (1&2) repeat 3x + Quad Flash 1 ALT 2 repeat 2x
8	POWER	POWER	POWER	Wave 1 ALT 2

ALT: Alternates

Note: If the user desires to have the capability of switching all the different flash patterns during operation, additional switches can be used.